

SYSTEM 4000 GMDSS

Less is more



SAILOR HF SSB 250W PEP One unit - many functions



SAILOR HF SSB 250W PEP is a part of Sailor's compact System 4000 GMDSS solution. It is an integrated HF radio with voice, DSC and radiotelex built into one unit, from one of the leading and most experienced manufacturers of maritime communication equipment in the world.

- Fully integrated control unit
- Simple and user-friendly soft-key based operation
- Graphic LCD display
- Built-in DSC and radiotelex modem
- Frequency range 100 kHz to 30 MHz continuous operation
- Built-in DSC watch-keeping receiver (1 or 6 ch. optional)
- Built-in power supply/battery charger (optional)



SAILOR

When safety counts

SAILOR HF SSB 250W PEP

One unit - many functions

Sailor has over 50 years experience in developing and manufacturing solutions for marine and point-to-point communication. The latest HF SSB system not only fully complies with all GMDSS safety requirements, it also sets new

standards in compactness, flexibility and convenience, making it a market leader in the field of professional HF radio-telephones.

The SAILOR HF SSB range features two configurations with different transmitter outputs. The SAILOR HF SSB 250W and 500W systems both offer voice transmission, Digital Selective Calling (DSC) and telex operation from one compact, multi-function control unit.

In addition, the unique SAILOR HF SSB set-up includes a microprocessor-controlled aerial unit, which automatically matches the impedance of 7-18 metres antennas, and finally, an outstanding transceiver unit with a combined 1 or 6-channel DSC and telex modem and a state-of-the-art MF/HF control unit.



Thanks to the system's logical user menus, accessing the most frequently used functions, such as radio operation, requires only the simplest of entries using the back-lit soft keys on the front panel of the control unit.

In a standard GMDSS telex configuration, a monitor or VDU/message processor is not needed. The GMDSS requirements for a radio telex system are fulfilled by using the function keys of the keyboard for dedicated telex functions, and by showing all received and transmitted messages directly on the printer.

If a SAILOR HF SSB is included in a System 4000 GMDSS set-up which is to be used intensively for radio telex transmission, a SAILOR DT4646E Data Terminal can be

connected to the transceiver unit.

Dedicating a data terminal to the radio telex in a GMDSS set-up makes it possible to monitor the telex communication, and the automated telex facilities makes it very simple to run the ship's telex

traffic unattended.

A highly reliable 24V DC power supply is as an integrated part of the 250W transceiver unit. It can also be supplied with a built-in AC power supply and a separate charger extension, which operates as a battery charger for the HF system.

The SAILOR HF SSB 500W system includes a 12/24-32V DC supply. A separate AC power supply can be delivered as either 1-phase or 3-phase, as well as a separate battery charger.

This makes the SAILOR HF SSB program even more flexible, integrated, and easy to install.

HT4520 TRANSCEIVER UNIT



Width: 440 mm
Height: 635 mm
Depth: 160 mm
Weight: 16 kg

HA4525 AERIAL COUPLER



Width: 290 mm
Height: 500 mm
Depth: 80 mm
Weight: 3.3 kg

LS4970 LOUDSPEAKER



Width: 100 mm
Height: 100 mm
Depth: 73 mm
Weight: 0.6 kg

HC4500 CONTROL UNIT



Width: 200 mm
Height: 100 mm
Depth: 95 mm (incl. cables)
Weight: 1 kg

TECHNICAL DATA

Complies with the relevant IMO performance standards, the ITU Regulations, the relevant ITU-R recommendations and meets the performance specifications of ETSI.

GENERAL

Frequency stability:	0.35 ppm.	
Operating modes:	Simplex and semi-duplex, SSB telephony, AM telephony, Telex and DSC.	
Supply voltage:	24V DC. With built-in AC Power Supply (optional): 110-120/220-240V AC (internal switch), 50/60 Hz automatic change-over to DC in the absence of AC supply.	
Supply voltage range:	DC: 21.6V to 31.2V. Power reduction below 26V. AC: $\pm 10\%$	
Current consumption:	RX only:	60W
	SSB unmodulated:	125W
	TX, SSB speech:	220W
	TX, SSB two-tone:	360W
	TX, FEC telex:	360W
	TX, DSC:	510W
Operating temp. range:	-20 °C to +55 °C	

RECEIVER

Frequency range:	100 kHz to 30 MHz
Aerial impedance:	50 Ω automatically matched by the aerial tuning unit
Input protection:	30V RMS (EMF)
IF selectivity:	SSB tel.: 350-2700 Hz
	AM tel.: ± 3 kHz
	Telex: ± 150 Hz
Sensitivity:	Aerial input for 10 dB SINAD, 50W aerial:
	SSB tel.: 0.6 μ V
	AM tel.: 4 μ V
	Telex: 0.25 μ V
Image rejection:	Greater than 80 dB
IF rejection:	Greater than 80 dB
Spurious rejection:	Greater than 80 dB
Int. gen. spur. signals:	Less than 5 dB SINAD (SSB)
Spurious emissions:	Less than 20pW/50W at aerial connector
Audio output power:	5W with less than 10% distortion

TRANSMITTER

Output power:	250W PEP ± 1.4 dB into 50 Ω , voice, DSC or ARO telex, 150W ± 1.4 dB into 50 Ω FEC telex, AC supply or min. 26V DC
Sgl. tone max. power:	250W ± 1.4 dB into 50 Ω for a duty cycle less than 55% and modulation rate greater than 3 baud. Reduction to 100W when continuously keyed during 1 minute. Automatic power recovery after 1 minute
Power reduction:	Medium power 60W Low approx. 10W
Frequency range:	ITU marine bands / 1605 kHz to 30 MHz
Intermodulation:	Better than -31 dB/PEP in standard two-tone test
Hum and noise:	Less than -50 dB PEP
Spurious emissions:	Less than -43 dB/PEP, typically better than -60 dB/PEP
Suppression of unwanted sideband:	Greater than 60 dB PEP (1 kHz, SSB)

DSC-TELEX MODEM

Protocols:	DSC:	ITU-R M. 493.7, M. 541-6, and M. 1082.
	Telex:	ITU-R M. 625-2 (incl. M. 476-4), M. 490, M. 491-1, and 492-5
Modes of operation:	Continuous DSC reception in combination with DSC or NBDP telex in ARQ, FEC and SELFEC modes	
Ship's identity:	DSC:	9-digit identity number
	Telex:	5- and/or 9-digit identity numbers
Interfaces:	Alarm:	DSC distress alarm interface
	NMEA:	NMEA 0183 interface for GPS equipment
	COM:	PC interface for SCANCOMM telex control. RS-232, baud rate 9600 bps
	[RCI]:	Remote transceiver control interface for control of frequency, mode and power level. T+Bus protocol, baud rate 2400 bps
	Line, Key:	Transceiver AF line input/output and external key interface. -10 to +10 dBm, 600W
	AUX alarm 2:	Telex and nondistress/urgency alarm output

DSC WATCH RECEIVER

Frequency range:	Single ch:	2187.5 kHz
	Scanning:	100 kHz to 30 MHz
Aerial impedance:	50 Ω	
Calling sensitivity:	Aerial input for symbol error rate below 1x10 ⁻² : 0 dB μ V	
Dynamic range:	With a wanted signal between 80 dB μ V and 0 dB μ V the symbol error rate is below 1x10 ⁻²	
Cond. spur. emission:	Less than 1 nW measured at the aerial connector	
Input protection:	30V RMS (EMF)	

BATTERY CHARGER EXTENSION

Charger type:	Automatic, with float charging. IE characteristic
Float charge voltage:	Adjustable 26.8 - 28.8V to voltage specified by battery manufacturer
Main charge current:	Min. 2A (receive condition)
Battery alarm output:	Make/break relay contacts 0.5A 32V
Alarm in case of:	Battery voltage too low (<23.4V) and battery voltage too high (adjustable 27-32V)
AC mains alarm output:	Make/break relay contacts 0.5A 32V
	Alarm in case of AC supply failure

AERIAL UNIT

Frequency range:	1.6 MHz - 30 MHz
Aerial requirements:	7-18 m wire and/or whip aerial
Aerial tuning:	Fully automatic with no presetting
Tuning speed:	0.1 - 0.5 sec
Power capability:	250W PEP 150W PEP ± 1.4 dB in 50 W above 4 MHz

Typical specifications subject to change without further notice.

CONFIGURATION

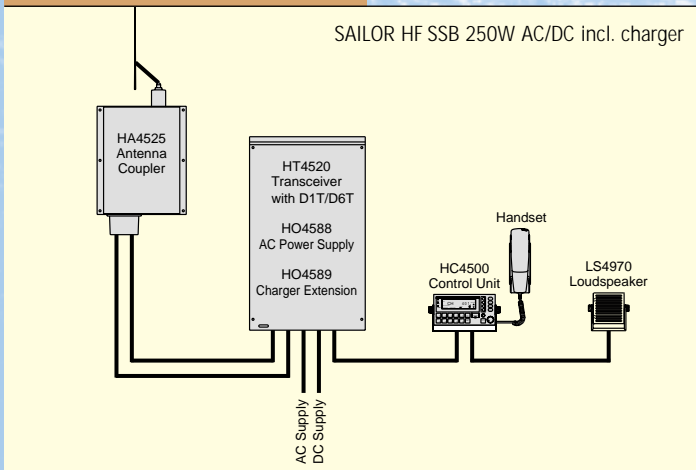

DIMENSIONS

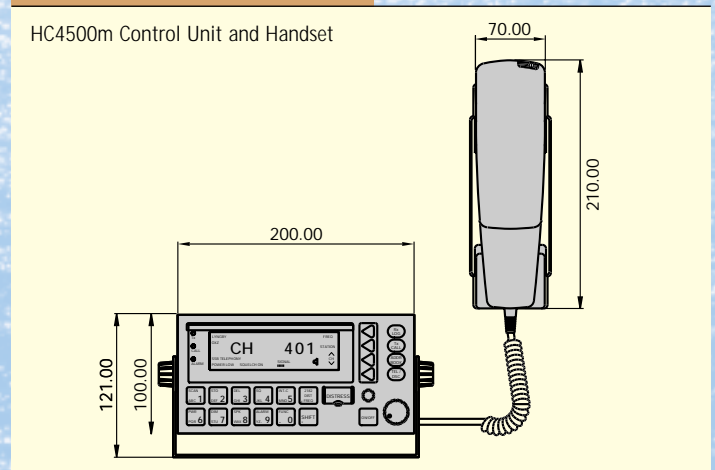



EVERYBODY KNOWS THAT A FRIEND IN NEED IS A FRIEND INDEED. For Sailor, however, it is not enough simply to be close at hand should problems arise. With Sailor maritime communication equipment you are always on safe ground, even when you are on the open sea. And safety is what counts on every vessel - for the crew as well as for the owner.

Ever since Mr. Simon Petersen founded the company S.P. Radio in 1948, the green Sailor radios have ruled the seven seas. After 50 years on the market, we have learned that a good reputation and loyal customers do not just appear of their own accord - they have to be earned.

WAVE-BREAKING TECHNOLOGY. Sailor has always been committed to pushing back boundaries and breaking new technological ground in order to meet the needs of our customers and to raise the safety standards of the market. Today, Sailor is a well-known line of communication products which includes everything from leisure market radios to equipment for fishing vessels of every size and complete communication solutions for the deep sea sector. The Sailor name has become a guarantee for reliable and technologically superior radio equipment ranging from basic VHF units to state-of-the-art satellite systems and complete compact GMDSS solutions.

TOMORROW'S SOLUTIONS AVAILABLE TODAY. S.P. Radio has been developing and manufacturing radios for more than 50 years, and we are ready for the challenges of the next millennium. Today, nearly 10% of our annual turnover is invested in product development and research, and more than one employee in ten is occupied with finding solutions to the challenges of tomorrow.

Whatever the future may bring, we are convinced that our green equipment will continue to dominate the seven seas. Because when you buy Sailor you buy safety.