

1 ZÖLLNER Makrofon Signal Set M 75F/370 ZVE

for vessels of a length of less than 75 m
- DHI 49/04 P/78 - Colregs 1972

design to print PZ 21 e
for connection to an existing compressed air pipe
of 6 to 40 bar
comprising:

- 1 Makrofon M 75 with straight sheet-steel horn
sound frequency 370 Hz
intensity in 1/3rd-octave band at 1 metre: 132 dB
- 1 Operating Valve ZVE 75
with adjustable pressure reducer, solenoid for
electric release AC 1phase
and with lever for manual release by pull-rope
- 1 Cover Screw Wrench
- 1 Set of Gaskets
- 1 Heating Device with Thermostat
AC 1phase, 100 Watt

In addition:

- 1 Second Electromagnet - please state voltage -
for emergency current to spare the pull-rope
according to SOLAS 1960 and 1974
- 1 Filter F 3 - R 1/2" - with Drain Cock
design to print SW 24

Spare Parts for Makrofon Set M 75/260 ZVE:

- 1 diaphragm M 75, single
- 1 solenoid coil - AC 1phase for ZVE 75
- 1 solenoid coil - emergency voltage

total approx. net weight 10 kg

*It is essential to have a filter inserted in the compressed air pipe before the Makrofon valve.
If this is not observed, guarantee claims cannot be accepted.

ZÖLLNERA Member of the **AVL** Group
SOUND SIGNAL EQUIPMENTP.O. BOX 6540 · D-24126 KIEL
ZUR FÄHRE 1 · D-24143 KIEL (GERMANY)
TELEPHONE: 0431/7027-113
TELEFAX: 0431/7027-202**ZÖLLNER-MAKROFON**
M 75 F + M 125
compressed air operated**General Features of the ZÖLLNER Makrofon Whistle**

Makrofon whistles are diaphragm sound transmitters. In water navigation as well as in road and rail-borne traffics, these whistles are unsurpassed because of their great sound intensity and audibility range. Besides, they are widely used in industrial plants as general and specific danger alarm systems and as rest indicating systems. Compressed air, carbonic acid etc. may be used to power the Makrofon.

The ZÖLLNER Makrofon is a reliable whistle distinguished by its low air consumption. Many thousands of Makrofon have been in service all over the world for decades. Owing to its simple construction the Makrofon is almost maintenance-free. It produces a pure note of wide range and its broad frequency spectrum shows many high harmonics. Please consider that signals containing many higher harmonics are able to penetrate an existing noise level even at a stage where the fundamental frequency proper is being absorbed. It is the residual sound that builds up the keynote in the human ear. Already two or three harmonics make the human ear perceive the fundamental frequency.

The electro-pneumatic Makrofon valve is provided with a heating with thermostatic regulator to heat its own body as well as the Makrofon casing.

Furthermore, this valve is equipped with a lever to attach the customer-provided hand pullrope. The expensive installation of a pullrope, which must be guided by pulleys and through tubes may be avoided. A second electromagnet working on the ship's emergency power supply should be installed instead, on the Makrofon valve ZVE. Please note that this release type meets SOLAS 1960 and SOLAS 1974 regulations.

The ZÖLLNER Makrofon is type-approved and meets the International Regulations for Preventing Collisions at Sea (IMO) 1972.

Certificates of ABS, BV, DOT, BSH, GL, LR, NV, RINA, PRS, etc. may be made available.

Positioning and Installation

It is absolutely necessary to place the Makrofon whistle as high as practical on a vessel to reduce interception of emitted sound by obstructions and to avoid hearing damage to the personnel. The sound pressure level of a vessel's own signal at listening posts must not exceed 110 dB (A).

Where possible, the compressed air pipe should be made of copper. If steel tubes are used instead, have an air filter directly precede the Makrofon valve in the pipe. Pipings of more than 10 m in length should have inside diameters (ID), which are larger than those shown on the tables hereafter (see applicable rules of the classification society/societies involved). Purge the pipe inside before applying compressed air. Only then link the line up.

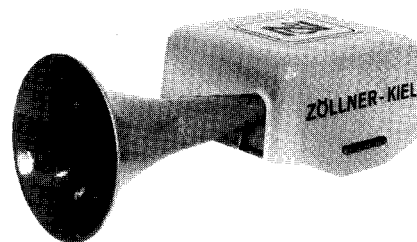

M 75 F

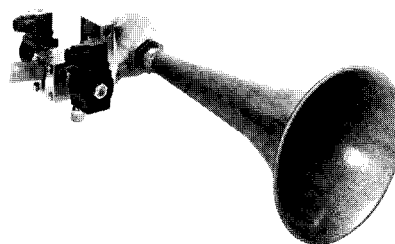

M 75 F

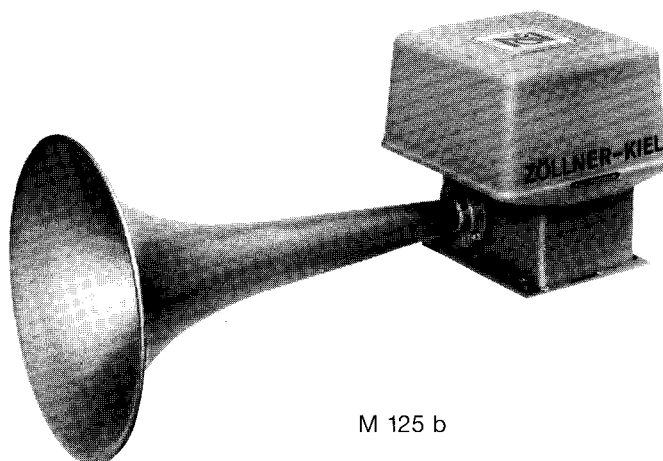

M 125 b

Marine Application according to COLREG 72
Ships less than 75 m in length (Class III + IV)

For these ships, a basic sound frequency of 250 - 700 Hz is required by COLREG 1972 rules. Makrofonen providing this frequency range have a straight sound horn made of sheet steel or, if requested, of sheet copper. And they may be furnished provided with electric heating and cover. If you want to spare the hand pullrope, a second magnet coil is required. This must be ordered separately by the customer.

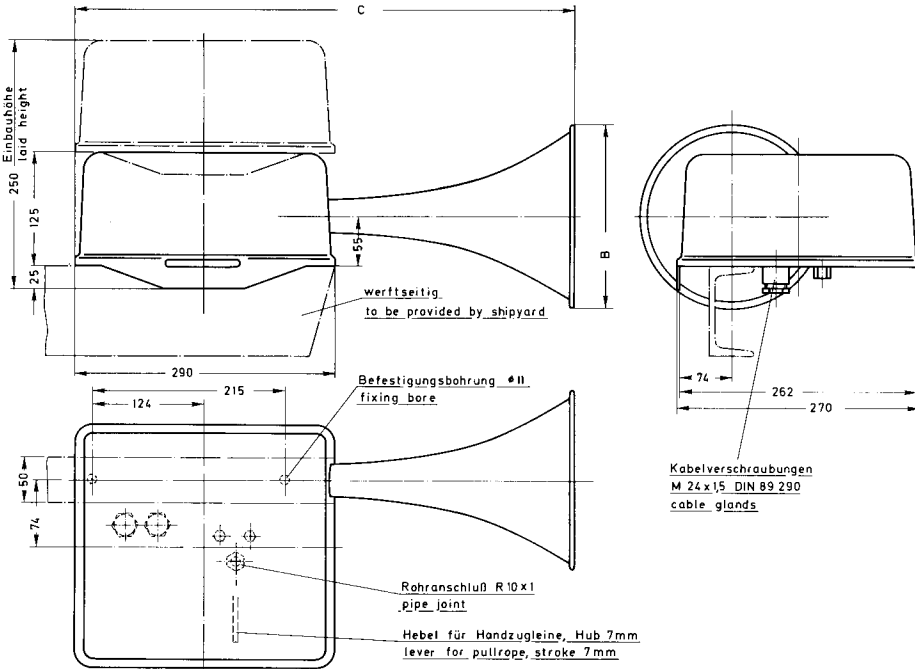

ship length metres	BSH class	type	basic frequency Hz	sound level at 1 m distance dB		consumpt. (free air) ltr/sec	air* pressure bar	pipe joint mm	dimensions mm			weight kg with			type test No. BSH
				1/3rd. oct.	min. level to IMO				A	B	C	1 valve	2 valve	2 valv. + heat.	
< 75	III + IV	M 75 F/370	370	132	130	8-12	6-40	Ø 10/8	380	200	560	4,4	5,0	7,1	49/04P/78
< 75	III + IV	M 75 F/320	310	138	130	8-12	6-40	Ø 10/8	480	225	660	4,8	5,4	8,0	49/04P/02/78
< 75**	III + IV	M 75 F/260	260	138	130	8-12	6-40	Ø 10/8	550	268	730	4,9	5,5	8,1	49/04P/03/82

* please state in purchase order ** may also be applied for ships' class II (length 75 - 200 metres)

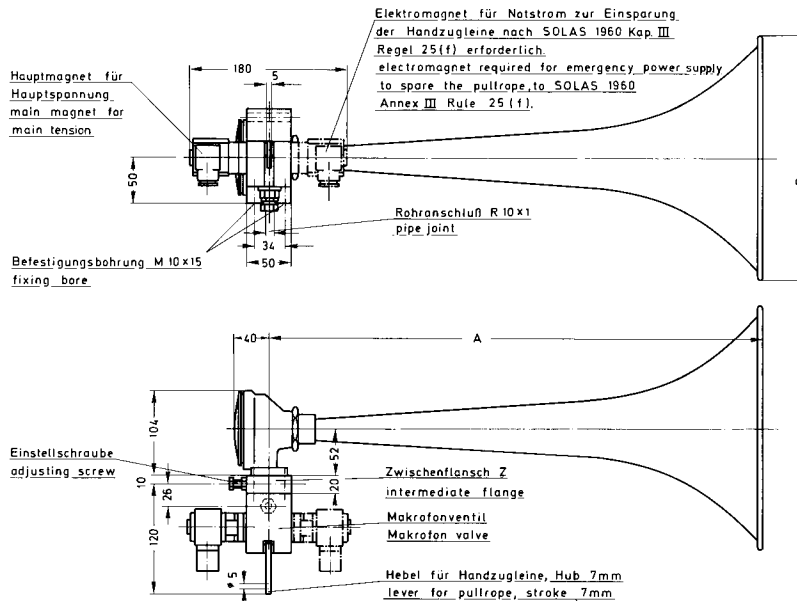

Kabelplan für Makrofon mit Heizung
Wiring diagram for Makrofon with heating

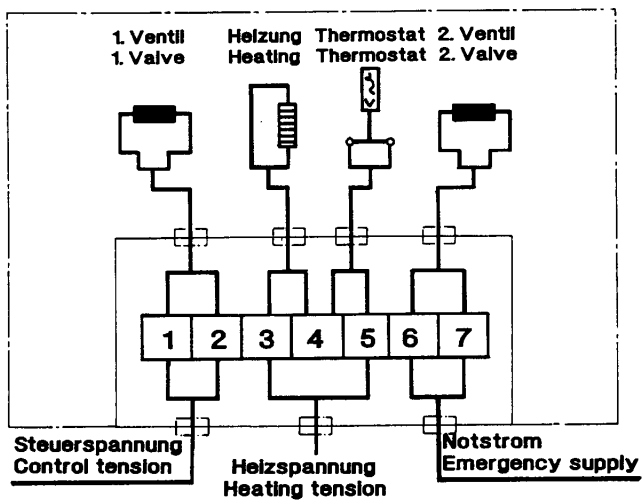

Kabelplan für Makrofon M 75 + M 125
ohne Heizung

wiring diagram for Makrofon M 75 + M 125
without heating

Hauptmagnet für
Hauptstrom
main magnet for
main tension

Elektromagnet für
Notstrom
elektromagnet for
emergency power

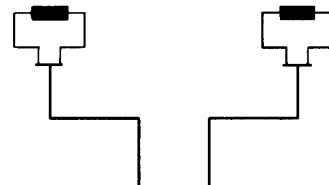

ZÖLLNER



KRAFTMASCHINEN—PRÜFSTÄNDE
AKUSTISCHE SIGNALANLAGEN

POSTFACH 6540 · D-24128 KIEL
ZUR FÄHRE 1 · D-24143 KIEL

TELEFON: (0431) 7027-113
TELEFAX: (0431) 7027-202

(GERMANY)
TELEX: 292 745
TELETEXT: 43 15 85

Druckluftfilter Compressed Air Filter

Bei Verlegung der Rohrleitung für die ZÖLLNER-Druckluftmakrofone muß ein Druckluftfilter vor dem Makrofonventil in die Rohrleitung eingebaut werden. Der Filter ist in einem temperaturschutzten Raum leicht zugänglich einzubauen, damit das anfallende Kondenswasser nicht einfrieren kann, und der Filter jederzeit gereinigt werden kann. Die Rohrleitung zwischen Filter und Makrofonventil muß aus rostfreiem Material, z.B. Kupfer, hergestellt werden.

Ein wirksamer Filter wird dazu beitragen,

- Produktionsausfälle zu vermeiden,
- Wartungskosten zu reduzieren,
- Reparaturkosten zu senken,
- Betriebssicherheit zu erhöhen,
- Garantieleistungen zu sichern.

Die Filter F 4 und F 3 haben einen leicht zu reinigenden Filtereinsatz aus Sinterbronze. Der Filter F 2 hat einen Siebschmutzfänger mit einer Maschenweite von 0,15 mm. Der Filtereinsatz für den Filter F 5 besteht aus Filterkeramik und Spezial-Kunststoff.

Der Druckluftfilter und Wasserabscheider NW 32 ist ein Düsen-Trockner, der eine gute Trocknung und Reinigung des durchströmenden Mediums bewirkt. Der Filter kann auch für Dampf verwendet werden! Bei den Filtern F 5, F 3 und F 2 kann das Ablassen des im unteren Teil angesammelten Wassers bzw. Kondensats von Hand durch ein Ablassventil erfolgen. Der Filter NW 32 ist mit einer automatischen Entwässerung ausgerüstet.

At pipe-laying for the ZÖLLNER Compressed Air Makrofon an air filter should be fitted into the piping directly before the Makrofon valve. The filter must be mounted in a warm room (no frost) with easy access so that condensed water cannot freeze, and the filter can be cleaned whenever necessary. The pipe between filter and Makrofon is to be made of stainless material such as, for instance, copper.

An effective filter will help

- avoiding breakdowns,
- reducing maintenance costs,
- reducing repair costs,
- guaranteeing reliable performance.

Filter F 3 and F 4 are provided with a filter insert of Sinter bronze which is easy to be cleaned. For the filter F 2 a dirt trap with a mesh aperture of 0.15 mm is used. The filter insert for the filter F 5 consists of filter ceramics and special plastic.

The compressed air filter and water separator NW 32 is a nozzle drier, effecting thorough drying and cleaning of the passing medium which may be either compressed air or steam. The filters F 5, F 3 and F 2 require hand discharge through a bottom outlet valve. The filter NW 32 is provided with an automatic draining device.

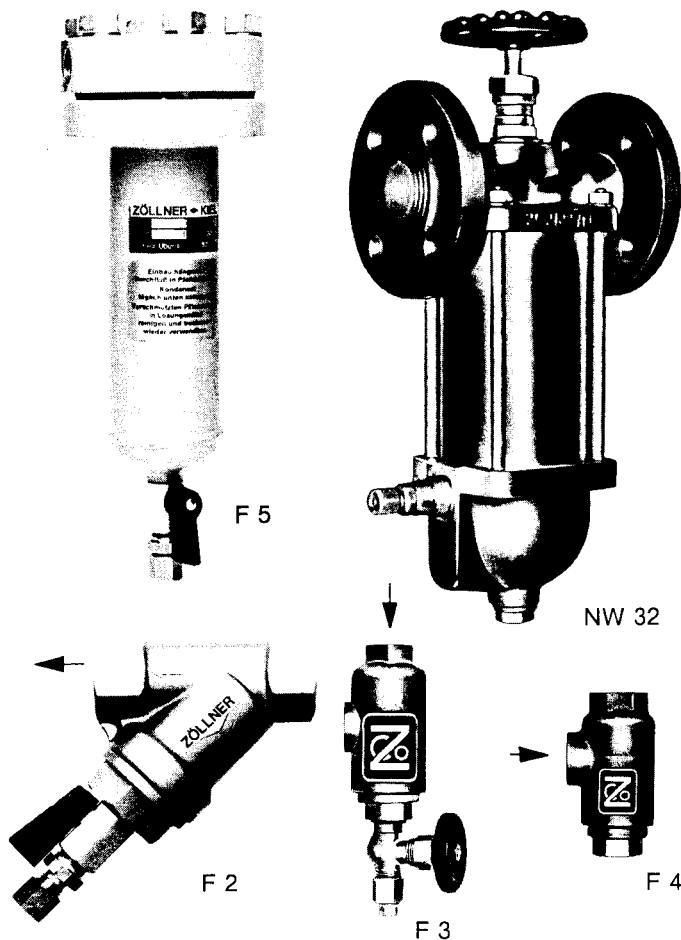

für Schiffslänge for length of vessel	Makrofontype Makrofon type Druckluft compressed air		Filtertype filter type
	6 - 16 bar	16 - 40 bar	
< 20 m	M 75	M 75	F 4
20 - 75 m	M 75	M 75	F 3/F 5
75 - 200 m	M 125 Rohrleitg. < 100 m pipe line	M 125	F 2
	M 125 Rohrleitg. > 100 m pipe line		
> 200 m		ZM 200 (ZM 300)	NW 32
		ZM 200 (ZM 300)	

< = kleiner als/less than

> = größer als/more than

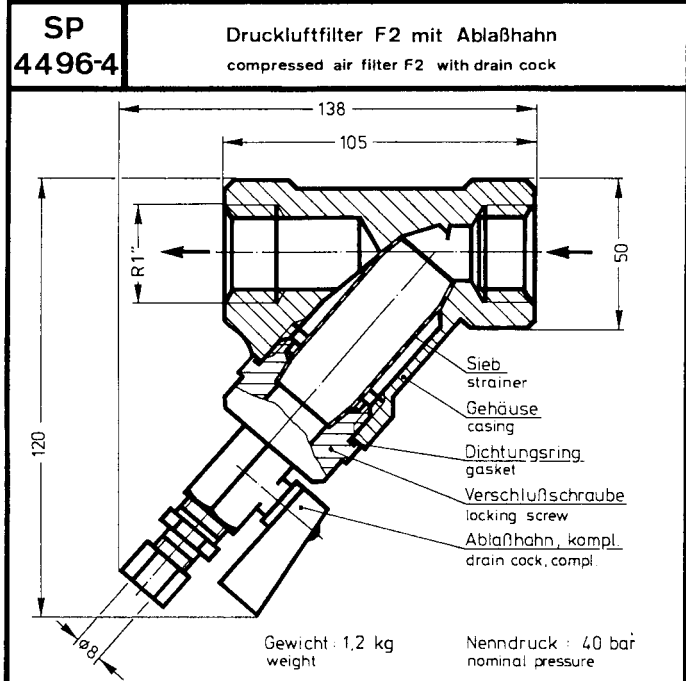
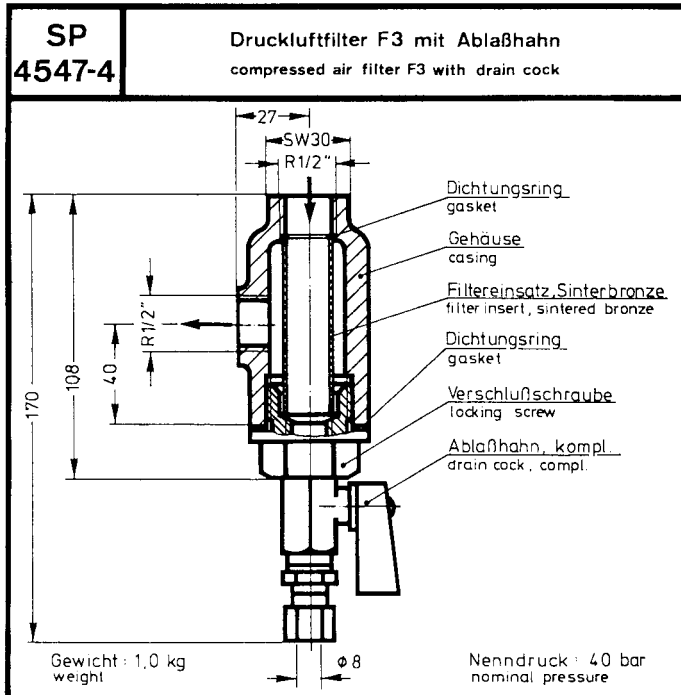
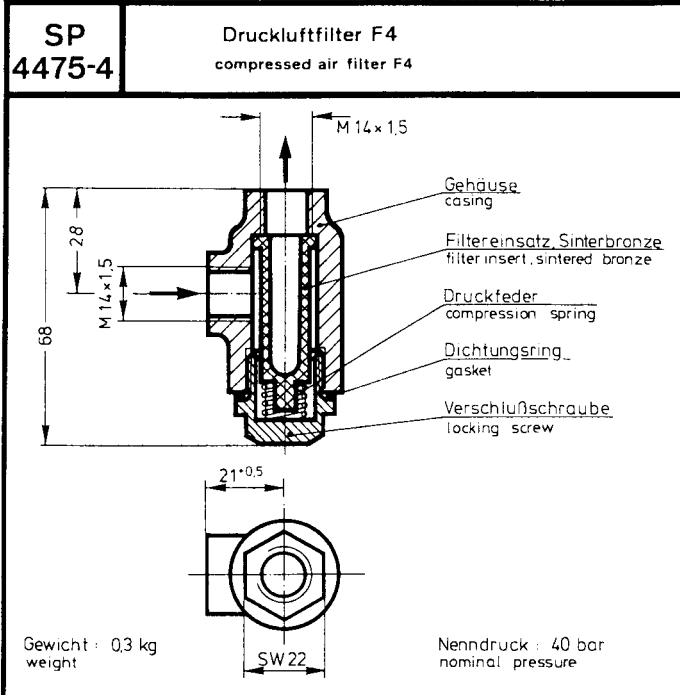

Änderungen vorbehalten!
subject to alteration!