

1 Makrofon Signal Set ZM 200/90 b ZVE

- BSH Class I - DHI 49/12 P/79 -

design to print PZ 32 e
for connection to an existing compressed air pipe
of 6 to 40 bar
comprising:

- 1 Makrofon ZM 200, bent , 90 degrees,
with sheet aluminum horn - sound frequency 90 Hz
intensity in 1/3rd-octave band at 1 metre: 143 dB
- 1 Sound Horn Support
- 1 Operating Valve ZVE 200
with adjustable pressure reducer, solenoid for
electric release AC 1phase
and with lever for manual release by pull-rope

1 Set of Gaskets

1 Heating Device with Thermostat
AC 1phase, 100 Watt

In addition:

1 Second Electromagnet
for emergency current to spare the pull-rope
according to SOLAS 1960 and 1974
? V DC or ? V AC 1phase (please indicate)

1 Filter F 2 - R 1" with Drain Cock
design to print SW 24

Spare Parts for Makrofon Set ZM 200/90 b ZVE:

- 1 diaphragm ZM 200
- 1 solenoid coil - AC 1phase for ZVE 200
- 1 solenoid coil - ? V AC or ? V DC

total approx. net weight 80 kg

*It is essential to have a filter inserted in the compressed air pipe before the Makrofon valve.
If this is not observed, guarantee claims cannot be accepted.

ZÖLLNER



ENGINE TEST BED DYNAMOMETERS
SOUND SIGNAL EQUIPMENT

ZUR FÄHRE 1

POSTBOX 6540

D-24143 KIEL

D-24126 KIEL

PHONE: (-431) 7027-113

TELEX: 292 746

TELEFAX: (-431) 7027-202 · TELETEXT: 4315 85

ZÖLLNER-MAKROFON ZM 200 compressed air operated

General Features of the ZÖLLNER Makrofon Whistle

Makrofon whistles are diaphragm sound transmitters. In water navigation as well as in road and rail-borne traffics, these whistles are unsurpassed because of their great sound intensity and audibility range. Besides, they are widely used in industrial plants as general and specific danger alarm systems and as rest indicating systems. Compressed air, carbonic acid etc. may be used to power the Makrofons.

The ZÖLLNER Makrofon is a reliable whistle distinguished by its low air consumption. Many thousands of Makrofons have been in service all over the world for decades. Owing to its simple construction the Makrofon is almost maintenance-free. It produces a pure note of wide range and its broad frequency spectrum shows many strong harmonics. Please consider that signals containing many upper harmonics are able to penetrate an existing noise level even at a stage where the fundamental frequency proper is being absorbed. It is the residual sound that builds up the keynote in the human ear. Already two or three harmonics make the human ear perceive the fundamental frequency.

The electro-pneumatic Makrofon valve is provided with a heating with thermostatic regulator to heat its own body as well as the Makrofon casing.

Furthermore, this valve is equipped with a lever to attach the customer-provided hand pullrope. The expensive installation of a pullrope, which must be guided by pulleys and through tubes may be avoided. A second electro-magnet working on the ship's emergency power supply should be installed instead, on the Makrofon valve ZVE. Please note that this release type meets SOLAS 1960 and SOLAS 1974 regulations.

The ZÖLLNER Makrofon is type-approved and meets the International Regulations for Preventing Collisions at Sea (IMO) 1972.

Certificates of ABS, BV, DOT, BSH, GL, LR, NV, RINA, PRS, ISSR-R., etc. may be made available.

Positioning and Installation

It is absolutely necessary to place the Makrofon whistle as high as practical on a vessel to reduce interception of emitted sound by obstructions and to avoid hearing damage to the personnel. The sound pressure level of a vessel's own signal at listening posts must not exceed 110 dB (A).

Where possible, the compressed air line should be made of copper. If steel tubes are used instead, have an air strainer directly precede the Makrofon valve in the line. Piping of more than 10 m in length should have inside diameters (ID), which are larger than those shown on the tables hereafter (see applicable rules of the classification company/companies involved). Purge the line inside before applying compressed air. Only then link the line up.

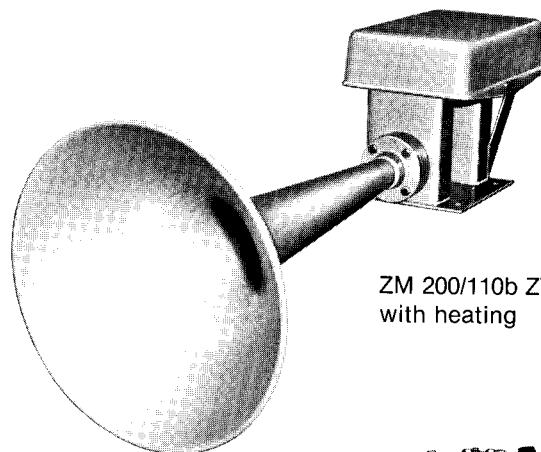

ZM 200/110b ZVE H
with heating

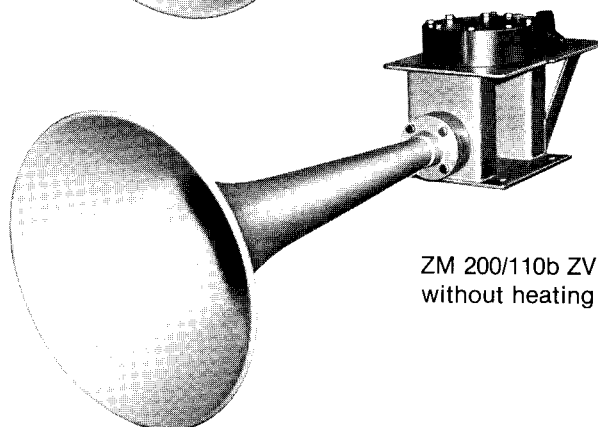

ZM 200/110b ZVE
without heating

Wiring diagram for Makrofon with heating

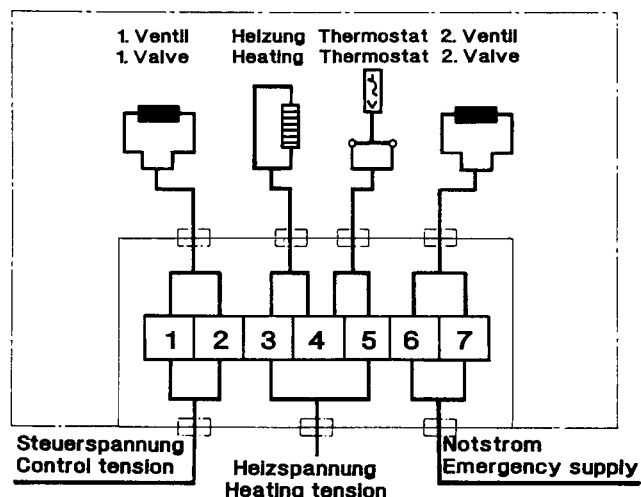

Marine Application according to IMO-Regulations

Ships to 200 m or more in length (Class I)

For these ships, a basic sound frequency of 70 - 200 Hz is required by IMO 1972 rules. Makrofon providing this frequency range have a sound horn bent by 90°. These sound horns are made either of sheet steel or, if desired, of light-metal or sheet copper. All of the ZM 200 b type Makrofon may be furnished provided with electric heating and cover. If you want to spare the hand pullrope, the second magnet coil is required. This must be ordered separately by the customer.

**Makrofon ZM 200/...b mit Heizung
Makrofon ZM 200/...b with heating**

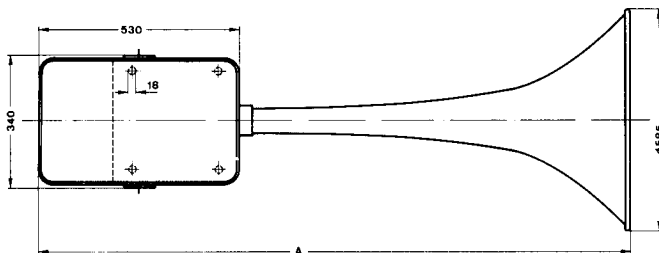
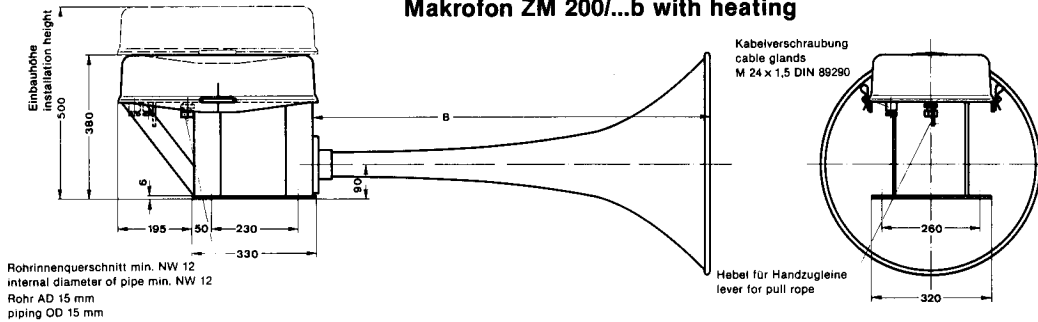

Pipings of more than 10 m in length should have inside diameters (ID), which are larger than those shown hereafter (see applicable rules of the classification company/companies involved).

ships length meters	class IMO	type	basic frequency Hz	sound level at 1 m distance dB		consumpt. (free air) ltr/sec	air* pressure bar	dimensions mm		weight kg with 2 valves	weight kg 2 valv. + heating	
				1/3 rd oct.	min. level to IMO			A	B			
≥ 200	I	ZM 200/110b	105	143	143	40-80	7-40	1570	1050	59,5	60,5	61,5
≥ 200	I	ZM 200/90b	90	143	143	40-80	7-40	1660	1140	60	61	62

* please indicate with purchase order

**Makrofon 200/...b ohne Heizung
Makrofon 200/...b without heating**

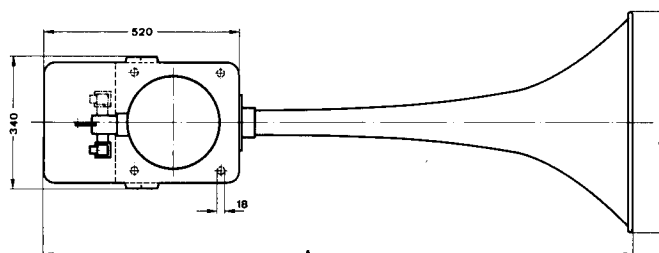
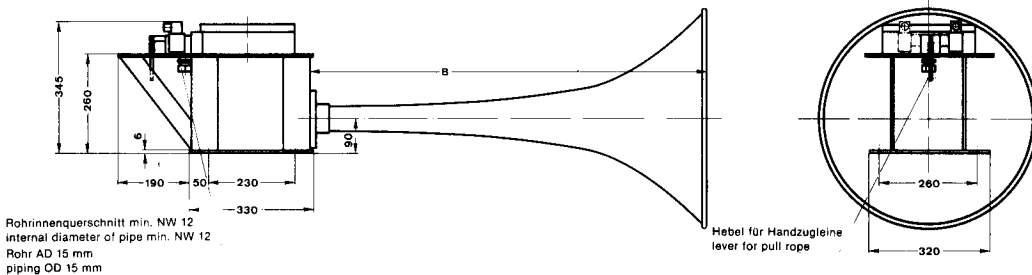

Pipings of more than 10 m in length should have inside diameters (ID), which are larger than those shown hereafter (see applicable rules of the classification company/companies involved).

ZÖLLNER



**KRAFTMASCHINEN—PRÜFSTÄNDE
AKUSTISCHE SIGNALANLAGEN**

POSTFACH 6540 · D-24128 KIEL
ZUR FÄHRE 1 · D-24143 KIEL

TELEFON: (0431) 7027-113
TELEFAX: (0431) 7027-202

(GERMANY)
TELEX: 292 745
TELETEXT: 43 15 85

Druckluftfilter Compressed Air Filter

Bei Verlegung der Rohrleitung für die ZÖLLNER-Druckluftmakrofone muß ein Druckluftfilter vor dem Makrofonventil in die Rohrleitung eingebaut werden. Der Filter ist in einem temperaturschutzten Raum leicht zugänglich einzubauen, damit das anfallende Kondenswasser nicht einfrieren kann, und der Filter jederzeit gereinigt werden kann. Die Rohrleitung zwischen Filter und Makrofonventil muß aus rostfreiem Material, z.B. Kupfer, hergestellt werden.

Ein wirksamer Filter wird dazu beitragen,

- Produktionsausfälle zu vermeiden,
- Wartungskosten zu reduzieren,
- Reparaturkosten zu senken,
- Betriebssicherheit zu erhöhen,
- Garantieleistungen zu sichern.

Die Filter F 4 und F 3 haben einen leicht zu reinigenden Filtereinsatz aus Sinterbronze. Der Filter F 2 hat einen Siebschmutzfänger mit einer Maschenweite von 0,15 mm. Der Filtereinsatz für den Filter F 5 besteht aus Filterkeramik und Spezial-Kunststoff.

Der Druckluftfilter und Wasserabscheider NW 32 ist ein Düsen-Trockner, der eine gute Trocknung und Reinigung des durchströmenden Mediums bewirkt. Der Filter kann auch für Dampf verwendet werden! Bei den Filtern F 5, F 3 und F 2 kann das Ablassen des im unteren Teil angesammelten Wassers bzw. Kondensats von Hand durch ein Ablassventil erfolgen. Der Filter NW 32 ist mit einer automatischen Entwässerung ausgerüstet.

At pipe-laying for the ZÖLLNER Compressed Air Makrofon an air filter should be fitted into the piping directly before the Makrofon valve. The filter must be mounted in a warm room (no frost) with easy access so that condensed water cannot freeze, and the filter can be cleaned whenever necessary. The pipe between filter and Makrofon is to be made of stainless material such as, for instance, copper.

An effective filter will help

- avoiding breakdowns,
- reducing maintenance costs,
- reducing repair costs,
- guaranteeing reliable performance.

Filter F 3 and F 4 are provided with a filter insert of Sinter bronze which is easy to be cleaned. For the filter F 2 a dirt trap with a mesh aperture of 0.15 mm is used. The filter insert for the filter F 5 consists of filter ceramics and special plastic.

The compressed air filter and water separator NW 32 is a nozzle drier, effecting thorough drying and cleaning of the passing medium which may be either compressed air or steam. The filters F 5, F 3 and F 2 require hand discharge through a bottom outlet valve. The filter NW 32 is provided with an automatic draining device.

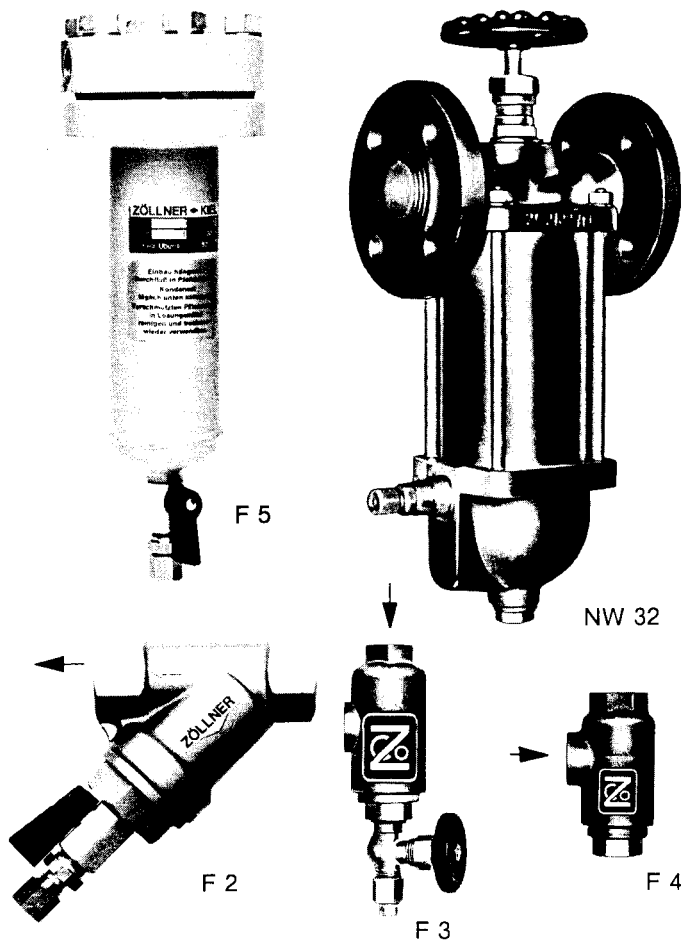

für Schiffslänge for length of vessel	Makrofontype Makrofon type Druckluft compressed air		Filtertype filter type
	6 - 16 bar	16 - 40 bar	
< 20 m	M 75	M 75	F 4
20 - 75 m	M 75	M 75	F 3/F 5
75 - 200 m	M 125 Rohrleitg. < 100 m pipe line	M 125	F 2
	M 125 Rohrleitg. > 100 m pipe line		
> 200 m		ZM 200 (ZM 300)	NW 32
		ZM 200 (ZM 300)	

< = kleiner als/less than

> = größer als/more than

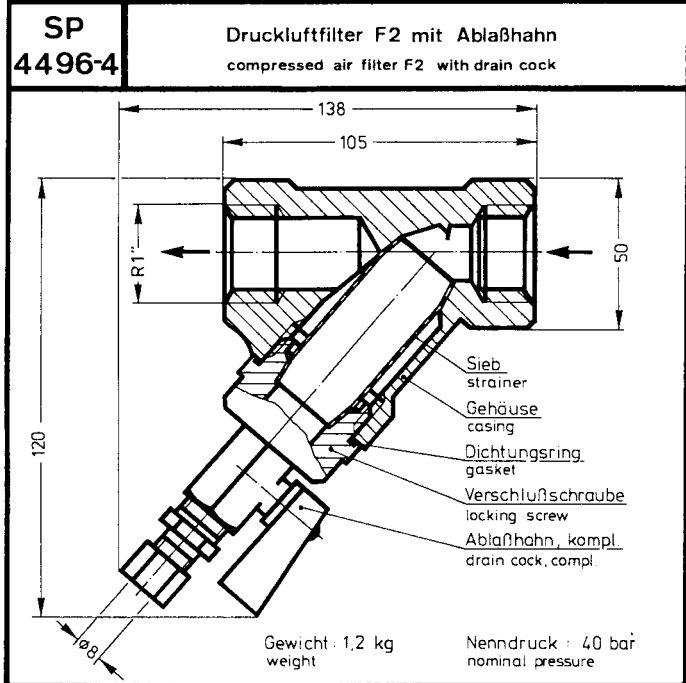
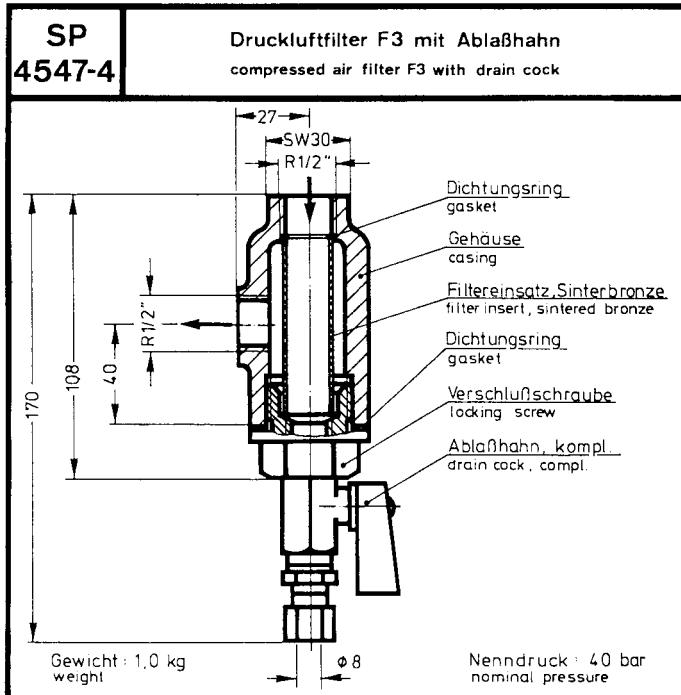
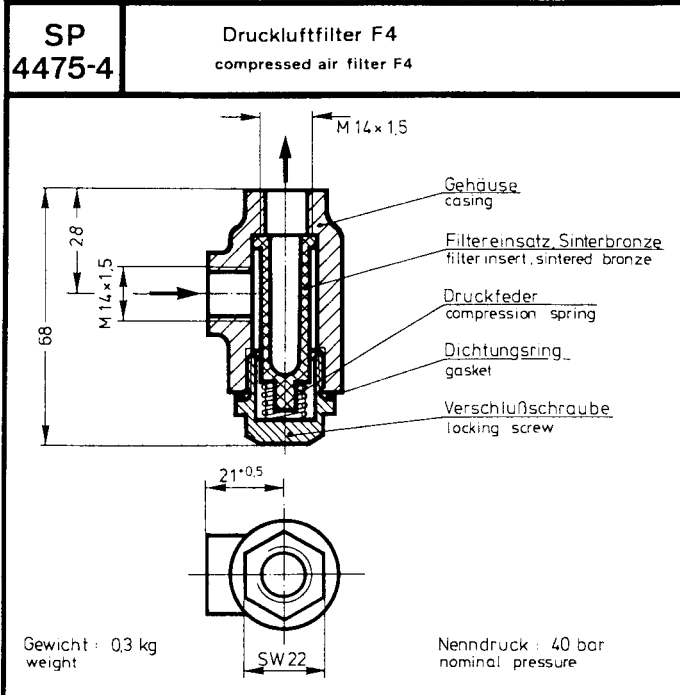

Änderungen vorbehalten!
subject to alteration!